



vetus

WWW.VETUS.COM



MANOEUVRING

BOW PRO SERIES

(R)EVOLUTION IN BOATING



TOTAL CONTROL

VETUS proudly presents the unique BOW PRO series

- Precision proportional boat control
- Suitable for high demanding applications (e.g. for use in rentals vessels)
- Endurance Rated Runtime*
- When paired with the BPPJA panel, single person docking is at your fingertips
- Maintenance-free brushless motor
- Efficient, safe & reliable



*BOW PRO thrusters run from 5, 6 or 10 minutes (dependant on Thruster model) at full power, after that power may reduce. At less than full power setting, run time is greatly enhanced. To achieve these results installation instructions must be adhered to. Battery state of charge, battery cable size, ambient temperature and other factors can effect thruster performance.



vetus

BOW PRO THRUSTER SERIES - best of both worlds!

(R)Evolution from VETUS: a combination of the renowned electric bow thruster series and the latest induction motor technology. We are pleased to present the all-new BOW PRO thrusters, the best of both worlds! Precision proportional control at your fingertips, you command as little or as much power as needed!



- Precision proportional control
- Endurance Rated Run-time - up to 10 minutes (dependant on model) at full power
- Maintenance-free brushless motor
- Sealed ingress protection construction - motor sealed for improved corrosion resistance in damp bilge environments
- Built-in over-temp and low battery voltage protection
- Suitable for high demanding applications (e.g. for use in rental & charter vessels)

Revolutionary concept matched with proven technology

Our BOW PRO thrusters use proven induction motors without carbon brushes. As a result, the bow thruster motor is maintenance-free and has Endurance Rated* run-time! Only the tailpiece anode and the power circuits need regular maintenance. The induction motor is controlled by the VETUS MCV motor controller which can handle both 12 volt or 24 volt on board systems, making the new BOW PRO thruster suitable for almost all boats. The built-in over-temp and low battery voltage protection, combined with the brushless induction motor make the BOW PRO thruster series highly resistant to abuse and ideal for beginning boaters and experienced captains!

The BOW PRO thruster is controlled by a proprietary CANBUS protocol (digital control) network. There are two fully-proportional panels available for the BOW PRO thruster series; one standard panel (BPPPA) and one panel with lock-and-hold capability for easy docking (BPPJA). BOW PRO thrusters utilize the same propellers and gearboxes proven in VETUS thrusters for over 30 years. Upgrading a boat with an existing thruster to a BOW PRO thruster is easily achieved as the BOW PRO thruster was made to share tunnel sizes with current VETUS thrusters as well as many other brands. The overview below shows which type and size boats are currently compatible with the BOW PRO series.

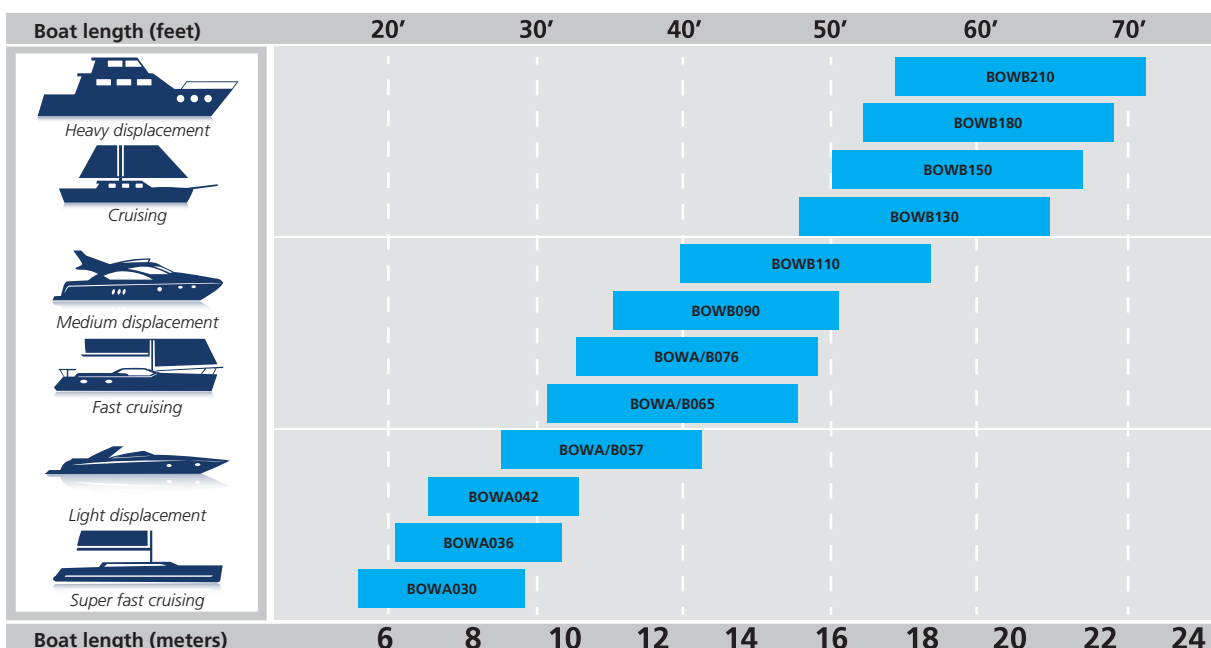

*BOW PRO thrusters run from 5, 6 or 10 minutes (dependant on Thruster model) at full power, after that power may reduce. At less than full power setting, run time is greatly enhanced. To achieve these results installation instructions must be adhered to. Battery state of charge, battery cable size, ambient temperature and other factors can effect thruster performance.



BOW PRO Thruster series (BOWA)

VETUS offers three ranges of BOW PRO thrusters: the BOW PRO series, the BOW PRO 48 volt series and the BOW PRO Boosted series. Listed in the table below are the technical specifications of the three BOW PRO series. Recommended battery sizes for the BOW PRO series are slightly larger than advised for conventional DC thrusters, to take full advantage of the motor efficiencies and resulting long run-times of these thrusters.

Specifications	BOW PRO 301	BOW PRO 361	BOW PRO 421	BOW PRO 571	BOW PRO 651	BOW PRO 761
Product code	BOWA0301	BOWA0361	BOWA0421	BOWA0571	BOWA0651	BOWA0761
Thrust in N (kgf) (power output)	300 (30)	360 (36)	420 (42)	550 (55)	650 (65)	760 (76)
Power kW	1,6	1,6	3,1	3,1	3,1	3,1
Brushless induction motor	✓	✓	✓	✓	✓	✓
Tunnel diameter, internal, mm	110	125	125	150	185	185
Weight excl. tunnel, in kg	24	24	35	35	35	35
For DC Systems, volt	12	12	12	12	12	12
Current consumption @ 12V, Amps.	174	240	218	295	237	322
Operating time						
- continuously at maximum thrust, in minutes	10	10	10	5	10	5
- at reduced thrust						
	Endurance rated*					
Main fuse	ZE250 (250 Amps)	ZE355 (355 Amps)	ZE355 (355 Amps)	ZE355 (355 Amps)	ZE355 (355 Amps)	ZE355 (355 Amps)
Batteries 12 volt D.C., min. Ah	1 x 85	1 x 125	1 x 105	1 x 120	1 x 125	1 x 125
Battery main switch, model BATSW	250	250	250	250	250	250

BOW PRO 48 volt Thruster series (BOWA) for electric propulsion

The increasing popularity of environmentally friendly boats with 48 volt electric propulsion required the development of thrusters running at the same voltage, and these BOWPROs are designed to meet that need. The three 48 volt BOW PRO thrusters offers all the advantages of the standard BOW PRO, are available in 3 propeller and tunnel diameters and are more than powerful enough to turn your runabout in the desired direction. In the table below are the technical specifications of the BOW PRO 48 volt series. Recommended battery sizes for the BOW PRO series are slightly larger than advised for conventional DC thrusters, to take full advantage of the motor efficiencies and resulting long run-times of these thrusters.

Specifications	BOW PRO 364	BOW PRO 574	BOW PRO 764
Product code	BOWA0364	BOWA0574	BOWA0764
Thrust in N (kgf) (effective power output)	360 (36)	570 (57)	760 (76)
Power kW	1,6	3,1	3,1
Brushless induction motor	✓	✓	✓
Tunnel diameter, internal, mm	125	150	185
Weight excl. tunnel, in kg	26	31	35
For DC Systems, volt	48	48	48
Current consumption @ 48V, Amps.	61	72	82
Operating time			
- continuously at maximum thrust, in minutes	10	10	10
- at reduced thrust			
	Endurance rated*		
Main fuse	ZE125 (125 Amps)	ZE125 (125 Amps)	ZE125 (125 Amps)
Batteries 12 volt D.C., min. Ah	4 x 60	4 x 55	4 x 60
Battery main switch, model BATSW	100	150	150



BOW PRO Boosted Thruster series (BOWB)

The hard charger of the thruster world

At the top of this advanced range of thrusters, VETUS offers the BOW PRO Boosted series (BOWB), innovative and significantly different from existing thrusters. All the features of the amazing BOW PRO with a bonus! There is a third connection on the motor, leading current to an internal charger which steps up the voltage from 12 to 24 volt, allowing a 12 volt charging source such as the propulsion engine alternator, to charge a 24 volt battery bank. Connecting the BOW PRO Boosted directly to a 24 volt power supply is also possible of course. The built-in charger recharges your battery bank when the thruster is not in use, doubling the value of having the BOW PRO Boosted thruster on your boat.



Recommended battery sizes for the BOW PRO Boosted series are slightly larger than advised for conventional DC thrusters, to take full advantage of the motor efficiencies and resulting long run-times of these thrusters.

Specifications	BOW PRO BOOSTED 57	BOW PRO BOOSTED 65	BOW PRO BOOSTED 76	BOW PRO BOOSTED 90	BOW PRO BOOSTED 110	BOW PRO BOOSTED 130	BOW PRO BOOSTED 150	BOW PRO BOOSTED 180	BOW PRO BOOSTED 210
Product code	BOWB057	BOWB065	BOWB076	BOWB090	BOWB110	BOWB130	BOWB150	BOWB180	BOWB210
Thrust in N (kgf) (power output)	570 (57)	650 (65)	760 (76)	900 (90)	1100 (110)	1300 (130)	1500 (150)	1800 (180)	2100 (210)
Power kW	3,1 kW (24V)	3,1 kW (24V)	3,1 kW (24V)	5,7 kW (24V)	5,7 kW (24V)	5,7 kW (24V)	5,7 kW (24V)	11 kW (48V)	11 kW (48V)
Brushless induction motor	✓	✓	✓	✓	✓	✓	✓	✓	✓
Tunnel diameter, internal, mm	150	185	185	185	185	185	250	250	250
Weight excl. tunnel, in kg	37	37	37	37	37	37	37	37	37
For DC Systems, volt	12 / 24	12 / 24	12 / 24	12 / 24	12 / 24	12 / 24	12 / 24	24 / 48	24 / 48
Current consumption @ 24 V, Amps.	141	119	166	192	288	290	242	185 @ 48 V	213 @ 48 V
Operating time - continuously at maximum thrust, in minutes - at reduced thrust	10	10	10	10	10	10	6	10	10
					Endurance rated*				
Main fuse	ZE250 (250 Amps)	ZE250 (250 Amps)	ZE250 (250 Amps)	ZE250 (250 Amps)	ZE355 (355 Amps)	ZE355 (355 Amps)	ZE355 (355 Amps)	ZE355 (355 Amps)	ZE355 (355 Amps)
Batteries 12 volt D.C., min. Ah	2 x 85	2 x 70	2 x 85	2 x 105	2 x 125	2 x 150	2 x 165	4 x 170	4 x 200
Battery main switch, model BATSW	250	250	250	250	250	250	250	250	250

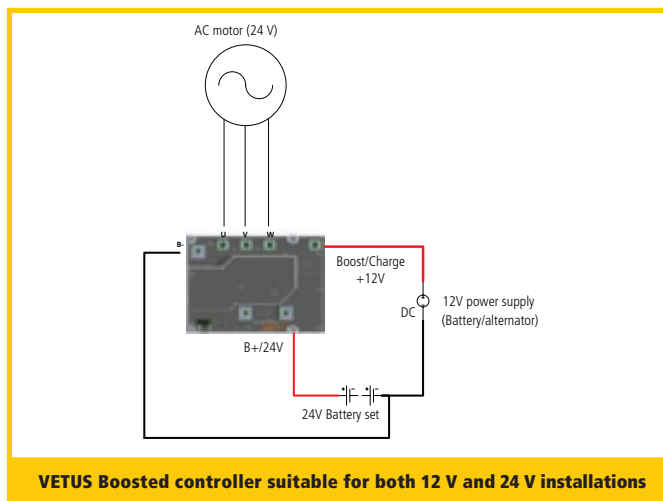
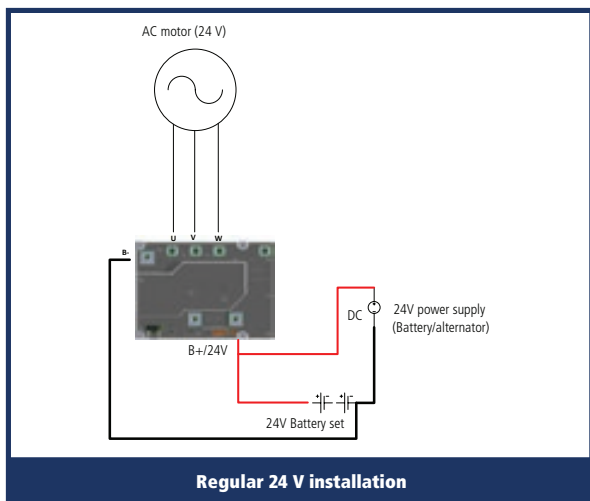

*BOW PRO thrusters run from 5, 6 or 10 minutes (dependant on Thruster model) at full power, after that power may reduce. At less than full power setting, run time is greatly enhanced. To achieve these results installation instructions must be adhered to. Battery state of charge, battery cable size, ambient temperature and other factors can effect thruster performance.



Examples of BOW PRO series thruster installations

The thruster you'll wish you'd had all along

BOW PRO Boosted thrusters are unique machines with intelligent motor controllers, in some applications providing more than just optimal boat control. Below we illustrate a couple of the many possible arrangements in installation.

Regular 12 volt connection (BOWA)

This is the scenario where the BOW PRO (BOWA) thrusters are installed just like every other thruster. The alternator delivers its output (either 12 volt, 24 volt or 48 volt) to the battery bank, which then distributes it to the various energy users. Plain and simple - the motor controller offers you the advantage of proportional control and Endurance-rated runtime*.

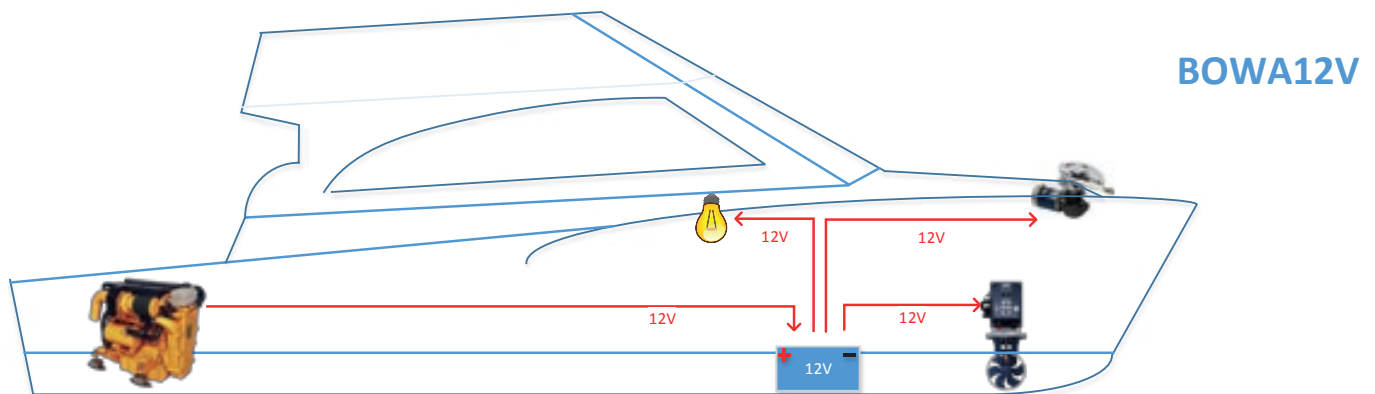

Boosted connection (BOWB): secondary power system

Here is where things get interesting: the 12 volt alternator of the propulsion engine feeds the main battery, which in turn feeds the BOW PRO Boosted (BOWB) motor controller. This converts the 12 volt input to a 24 volt charging current for the secondary battery bank. Depending on which battery bank you choose, this gives you the freedom to choose between 12 volt and 24 volt on board equipment. From the 24 volt power bank you can use high efficiency 24 volt equipment such as windlasses and power winches. At the higher voltage and consequent lower amperage, your vessel can use smaller battery cables, making equipment like winches easier to accommodate. However if 12 volt equipment is already installed on your vessel, you can also choose to stick with the 12 volt system. The choice is yours! In short the addition of a BOW PRO Boosted thrusters enables a secondary power system on board from your regular 12 volt alternator!

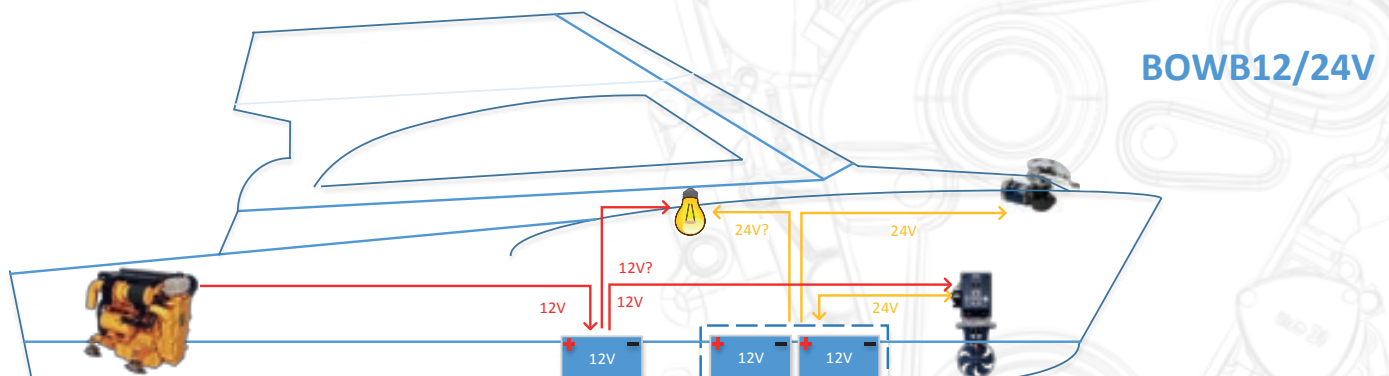

*BOW PRO thrusters run from 5, 6 or 10 minutes (dependant on Thruster model) at full power, after that power may reduce. At less than full power setting, run time is greatly enhanced. To achieve these results installation instructions must be adhered to. Battery state of charge, battery cable size, ambient temperature and other factors can effect thruster performance.

BOW PRO Series Auxiliary items

BOW PRO thrusters are controlled by one of the following panels (available separately). Selecting the correct model depends on your personal preference and needs, as all panels are plug-and-play. See below for the specifications for each model.

BPPPA Panel

- Compact design and high quality materials
- Safe and easy proportional control of your vessel
- Aluminium bezel
- Quick installation in Ø 75 mm cut-out hole
- Waterproof housing IP65
- V-CAN CANBUS protocol compliant
- Twin connector for multiple stations
- Status indicator



BPPJA Panel

- Compact design and high quality materials
- Safe and easy proportional control of your vessel
- Aluminium bezel
- Quick installation in Ø 75 mm cut-out hole
- Waterproof housing IP65
- V-CAN CANBUS protocol compliant
- Twin connector for multiple stations
- Status indicator
- With thruster hold and lock function



DBPPJA Panel

- Controls both bow and stern thruster
- Unique twist function to rotate the boat
- Compact design and high quality materials
- Safe and easy proportional control of your vessel
- Aluminium bezel
- Easy installation in Ø 75 mm cut-out
- Waterproof housing IP65
- V-CAN CANBUS protocol compliant
- Status indicator
- With hold and lock function



Installing a BOW PRO series thruster also requires:

- CAN cables (BPCABCxxM)
- Gender changer cable (BPCABCGC)
- CAN supply cable (BPCABCPC)
- CAN 3 point hub (BPCANHUB)
- CAN termination resistor (BPCANT).

3 year warranty, unique in the market!

All VETUS boat equipment products come with a 3 year warranty. As a result of our long experience, careful choice of materials and stringent quality controls, we have the confidence to offer this warranty. For advice, installation and service you can always rely on our worldwide network of VETUS dealers.





Dimensions of all BOW PRO Thrusters (in mm)

SERIES	BOWA	BOWA	BOWA BOWB	BOWA BOWB	BOWA BOWB	BOWA BOWB	BOWB	BOWB	BOWB	BOWB
Output	30 KgF	36 KgF	42 KgF	55 / 57 KgF	65 KgF	76 KgF	90 KgF	110 KgF	130 KgF	150 / 180 / 210 KgF
A	210	210	210	210	210	210	282	282	282	282
B	350	358	378	434	450	450	452	452	452	528
E Ø	200	200	200	200	200	200	200	200	200	240
F Ø	110	125	125	150	185	185	185	185	185	250

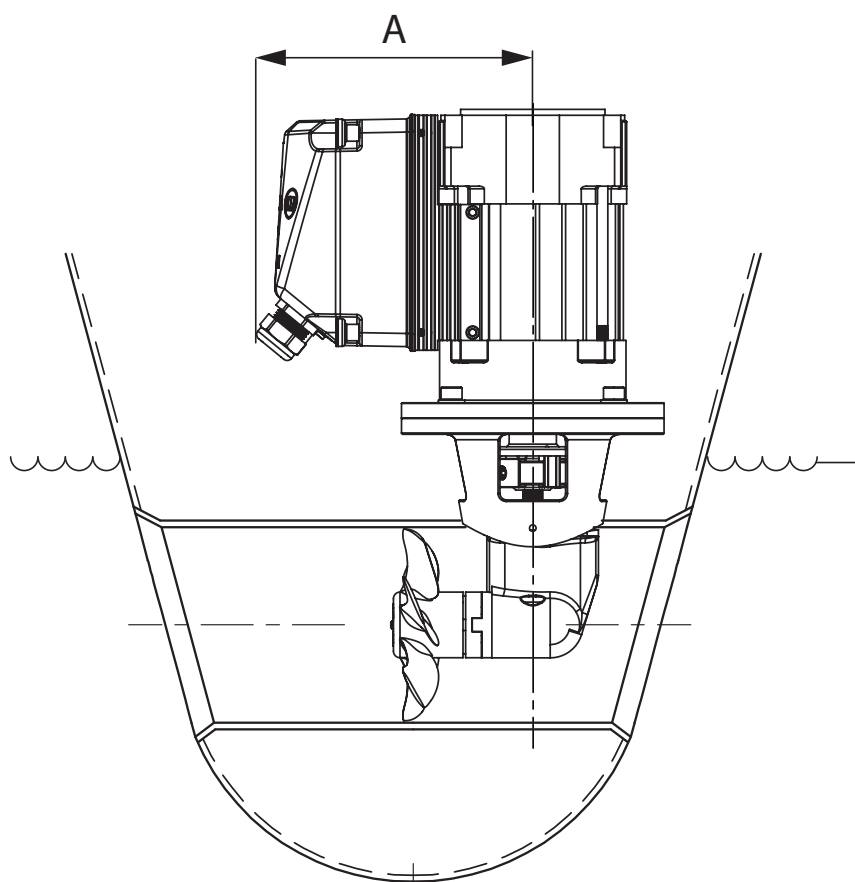
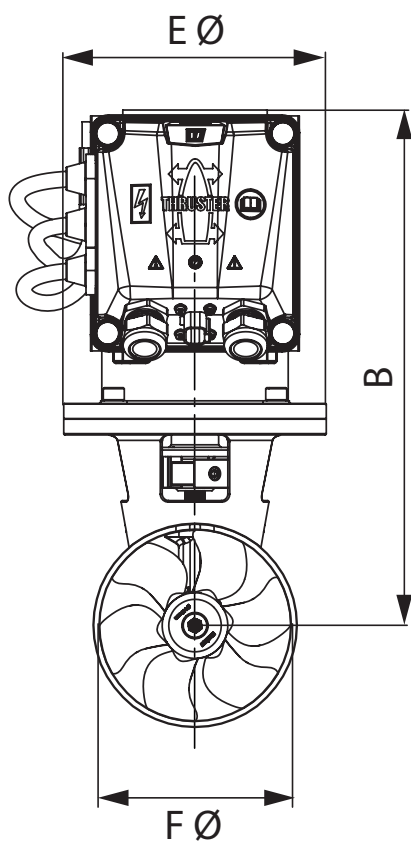



BOW PRO Boosted Series compared to..

The technical advantage over existing thrusters are significant when compared with our competitors:

Comparison	BOW PRO 301	Sidepower SEP30S	Quick	Lewmar
Thrust, N (kgf)	300 (30)	300 (30)	300 (30)	280 (28)
Efficiency >80%	✓	No	No	No
CANBUS	✓	✓	No	No
Proportional	✓	✓	No	No
Brushless	✓	No	No	No
Input voltage	12 V or 24 V	12 V or 24 V	12 V or 24 V	12 V or 24 V
Operating time	Endurance-rated*	5 min	N/A	N/A

Comparison	BOW PRO BOOSTED 90	Sidepower SEP80	Quick BTQ185-95	Maxpower CT80	Lewmar 185TT5.0
Thrust, N (kgf)	900 (90)	800 (80)	950 (95)	690 (69)	820 (82)
Efficiency >80%	✓	No	No	No	No
CANBUS	✓	✓	No	No	No
Proportional	✓	✓	Optional	Optional	No
Brushless	✓	No	No	No	No
Input voltage	12 V & 24 V	12 V or 24 V	12 V or 24 V	12 V or 24 V	12 V or 24 V
Operating time	Endurance-rated*	5 min	N/A	2-3 min	N/A

Endurance Rated* run-time & proportional control

When you've been out on a boat with a BOW PRO, you'll realize that this is a big step forward in boat control! These thrusters are the evolution of the conventional thrusters and the line-up will be expanded during 2020 so keep an eye on our website.



*BOW PRO thrusters run from 5, 6 or 10 minutes (dependant on Thruster model) at full power, after that power may reduce. At less than full power setting, run time is greatly enhanced. To achieve these results installation instructions must be adhered to. Battery state of charge, battery cable size, ambient temperature and other factors can effect thruster performance.